

# Refrigerated Display Cabinet Test Report

**Test Laboratory Name/Address**  
 Laboratory of FROST TECH(Guangzhou) Refrigeration Facilities CO.,LTD.  
 Xiaowu Industrial Zone Dongchong Town,Nansha District,Guangzhou,  
 Guangdong Province,P.R.China.

**Manufacturing Name/Address**  
 FROST TECH(Guangzhou) Refrigeration Facilities CO.,LTD.  
 Xiaowu Industrial Zone Dongchong Town,Nansha District,Guangzhou,  
 Guangdong Province,P.R.China.

Brand Name	FROST TECH
Product	Refrigerated display cabinet
Description	The product covered by this report is a commercial used, cord connected refrigerated display cabinet.
Model(s)	ECO MD60/150
Voltage/Frequency	220-240V,50Hz
Rating current	11.18A
Drip tray Rating current	3A
Teststandard(s)orcriteria(s)	(EU)2019/2018 (EU)2019/2024 ENISO23953-2:2015

**Conclusion**  
 The results are in compliance with the requirements of the EC regulation 2019/2024.  
 Energy efficiency class: E



Prepared by: He Jianjin



Name plate:

<b>COMMERCIAL DISPLAY CABINET</b>	
Model	ECO MD60/150
Voltage/Frequency	220-240/50Hz
Rating current	14.18A
Refrigerant	R452A / R404A (R290 Available)
Compressor	Tecumseh CAJ9510Z
Controller	LAE LF28DE
Vesicant	CO2

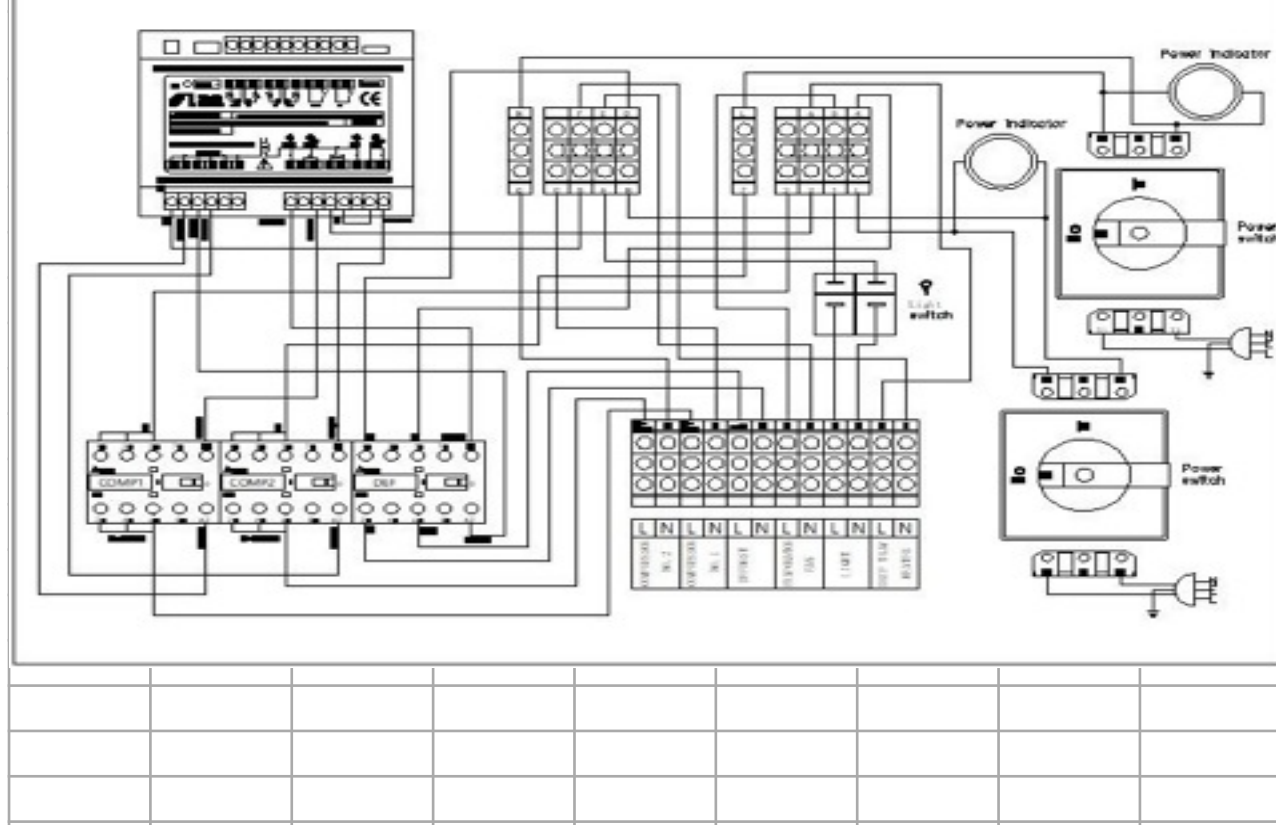
Name: FROST TECH  
 Address: Xiaowu Industrial Zone Dongchong Town, Nansha



Product details:

Cabinet family code	VC2
Cabinet type	Integral
Model number of Unit Under Tested	ECO MD60/150
Brand name	FROST TECH
Operating temperature(s)	Chilled
Category	Vertical and combined supermarket refrigerator cabinets
Energy efficiency class	E
Climate class	3
M Package Temperature Class	M2
Doors	N/A
Shelves	4 shelves
Light	LED TUBE T8
Refrigerant	R452A / R404A (R290 Available)
Charge of refrigerant(g)	950g
Over all dimensions(W*D*H)[mm]	600*1500*1950

Performance parameter:

Highest temperature of the warmest M-package of the compartment(s) with chilled operating temperatures (°C)	+7
Lowest temperature of the coldest M-package of the compartment(s) with chilled operating temperatures, or the highest minimum temperature of all M-packages of the compartment(s) with chilled operating temperatures (°C)	-1

Critical Components:

Name	Manufacturer/trademark	Type/model	Technical data
Compressor	TECUMSEH	CAJ9510Z	220-240V,50Hz
Controller	LAE	LF28DE	220-240V,50Hz

Test Condition:

Dry Bulb	25±1°C
Relative humidity	60±3%
Input Voltage	230V
Input Frequency	50Hz

Temperature and total display area Tests:

Temperature Class	Symbol	Temperature Test (°C)			Total display area test (m <sup>2</sup> )
		Temperature	Limit	Verdict	
M2	θah	6.4	≤7	Pass	2.7
	θb	0.5	≥-1	Pass	

Calculation for EEI and conclusion:

Total display area TDA(m <sup>2</sup> )	2.7
M	9.1
N	9.100
P	1.1
Y	2.7
C	1
Calculation formula	SAE: 365 * P * (M + N * Y) * C
Standard annual energy consumption SAE (Kwh/24h)	13518.5
Daily energy consumption E <sub>daily</sub> (kWh/24h)	24
Annual energy consumption AE (kWh/a)	8761
Energy Efficiency Index EEI	64.8
Energy efficiency class	E
From 1 March 2021: EEI < 100, Ice-cream freezers: EEI < 80	Pass
From 1 September 2023: EEI < 80, Ice-cream freezers: EEI < 50	Pass

