

Refrigerated Upright Storage Cabinet Test Report

Test Laboratory Name/Address

Laboratory of FROST TECH(Guangzhou) Refrigeration Facilities CO.,LTD.
Xiaowu Industrial Zone Dongchong Town,Nansha District,Guangzhou,
Guangdong Province,P.R.China.

Manufacturing Name/Address

FROST TECH(Guangzhou) Refrigeration Facilities CO.,LTD.
Xiaowu Industrial Zone Dongchong Town,Nansha District,Guangzhou,
Guangdong Province,P.R.China.

Brand Name	FROST TECH
Product	Refrigerated upright storage cabinet
Description	The product covered by this report is a commercial used,cord connected refrigerated upright storage cabinet.
Model(s)	ECO-GN700M
Voltage/Frequency	220-240V,50Hz
Rating current	1.8A
Test standard(s)or criteria(s)	(EU)2019/2018 (EU)2019/2024 ENISO23953-2:2015
Conclusion	The results are incompliance with there requirements of the EC regulation 2019/2024. Energy efficiency class: B

Prepared by:He Jianjin

Photo 1 - Front view:



Name plate:

COMMERCIAL STORAGE CABINET	
Model	ECO-GN700M
Voltage/Frequency	220-240/50Hz
Rating current	1.8A
Refrigerant	R134A/220g
Compressor	Tecumseh AE4425Y
Controller	DIXEL XR02CX
Vesicant	Cyclopentane

Name:FROST TECH

Address:Xiaowu Industrial Zone Dongchong Town,Nansha District,Guangzhou,Guangdong Province,P.R.China.

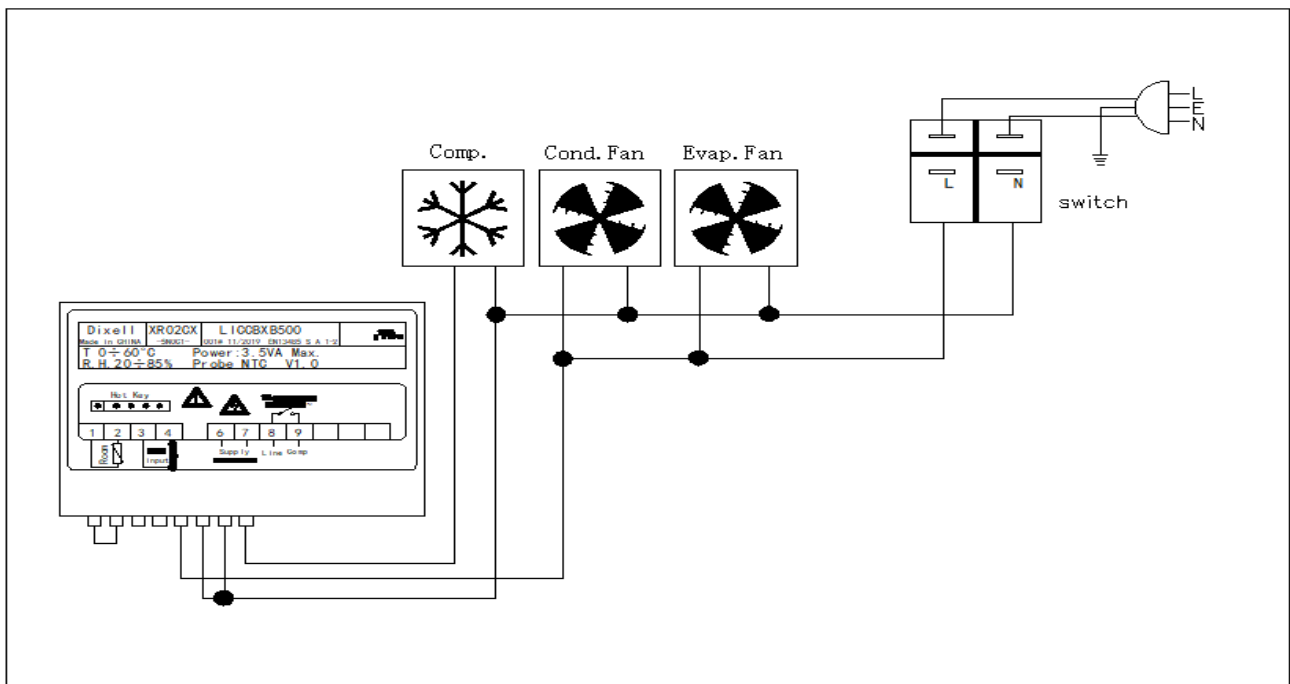

Product details:

Cabinet family code	SRV-ND
Cabinet type	Integral
Exterior body	Silver
Interior body	Aluminium
Model number of Unit Under Tested	ECO-GN700M
Brand name	FROST TECH
Operating temperature(s)	Chilled
Category	Vertical Storage refrigerator cabinets
Energy efficiency class	B
Climate class	4
M Package Temperature Class	M2
Doors	1 Self-closing hinged door
Shelves	5 adjustable shelves
Light	N/A
Refrigerant	R134A
Charge of refrigerant(g)	220g
Over all dimensions(W*D*H)[mm]	730*880*2010

Performance parameter:

Highest temperature of the warmest M-package of the compartment(s) with chilled operating temperatures	+7 °C
Lowest temperature of the coldest M-package of the compartment(s) with chilled operating temperatures, or the highest minimum temperature of all M-packages of the compartment(s) with chilled operating temperatures (°C)	-1 °C

Critical Components:

Name	Manufacturer/trademark	Type/model	Technical data
Compressor	TECUMSEH	AE4425Y	220-240V,50Hz
Controller	DIXEL	XR02CX	220-240V,50Hz

Test Condition:

Dry Bulb	30±1°C
Relative humidity	55±3%
Input Voltage	230V
InputFrequency	50Hz

Temperature and total display area Tests:

Temperature Class	Symbol	TemperatureTest(°C)			Total Volume Liters
		Temperature	Limit	Verdict	
M2	θah	4.8	≤7	Pass	620
	θb	2.1	≥-1	Pass	

Calculation for EEI and conclusion:

Total Volume/Liters	620
M	1.643
N	609
Vn	620
Calculation formula	SAEC=(M*Vn)+N
Standard annual engery consumption SAEC (KWh/a)	1627.66
Daily energy consumption Edaily (kWh/24h)	1.53
Annual energy consumption AEC(kWh/a)	560
Energy Efficiency Index EEI=AEC/SAEC	34.4
Energy efficiency class	B
	Pass

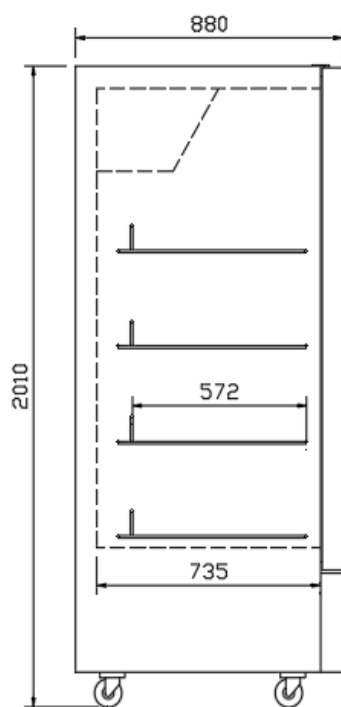
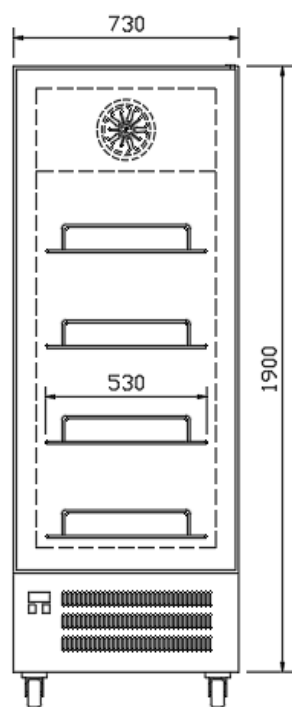

Type	Length	Depth	Height	Nom. voltage/ frequency	Electrical fusing	Temperature range
ECO GN700M	730 mm	880 mm	2010 mm	230 V/50 Hz	13A, slow	0 ... +7 °C